

Alfa Laval

Unique Mixproof CIP

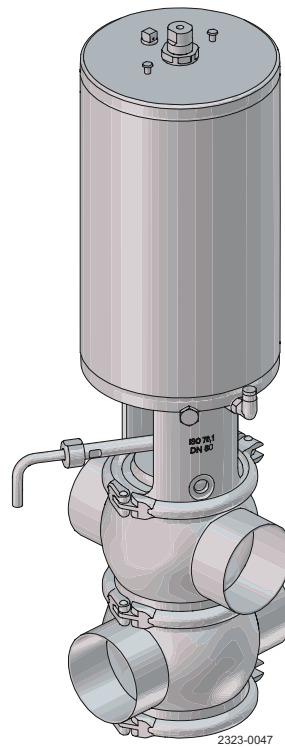

Lit. Code 200008438-1-EN-GB
Manual No. 100008412

Instruction Manual

Published by
Alfa Laval Kolding A/S
Albuen 31
DK-6000 Kolding, Denmark
+45 79 32 22 00

The original instructions are in English

© Alfa Laval Corporate AB 2023-05

This document and its contents are subject to copyrights and other intellectual property rights owned by Alfa Laval Corporate AB. No part of this document may be copied, re-produced or transmitted in any form or by any means, or for any purpose, without Alfa Laval Corporate AB's prior express written permission. Information and services provided in this document are made as a benefit and service to the user, and no representations or warranties are made about the accuracy or suitability of this information and these services for any purpose. All rights are reserved.

Contents

1	Declarations of Conformity	5
1.1	EU Declaration of Conformity.....	5
1.2	UK Declaration of Conformity.....	6
2	Safety	7
2.1	Important information.....	7
2.2	Warning signs.....	8
2.3	Safety precautions.....	9
3	Installation	11
3.1	Unpacking/delivery.....	11
3.2	Installation.....	14
3.3	Welding.....	16
3.4	Recycling Information.....	18
4	Operation	19
4.1	Fault finding and repair.....	20
4.2	Recommended cleaning.....	21
5	Maintenance	23
5.1	General maintenance.....	23
5.2	Actuator Bushing Replacement (Non-maintainable Actuator).....	25
5.3	Dismantling the valve.....	28
5.4	Upper and lower plug seal replacement.....	30
5.5	Valve assembly.....	33
6	Technical data	37
7	Spare Parts	39
7.1	Ordering Spare Parts.....	39
7.2	Alfa Laval Service.....	39
8	Parts list and exploded view	41

1 Declarations of Conformity

1.1 EU Declaration of Conformity

The Designation Company

Alfa Laval Kolding A/S, Albuen 31, DK-6000 Kolding, Denmark, phone no. +45 79 32 22 00

Company name, address and phone number

Hereby declare that

Valve

Designation

Alfa Laval "Unigue Mixproof CIP"

Type

From serial number 1181354 to 9999999

is in conformity with Machinery Directive 2006/42/EC

The person authorised to compile the technical file is the signer of this document.

Global Product Quality Manager
Pump, Valves, Fittings and Tank Equipment

Title

Lars Kruse Andersen

Name

Kolding, Denmark

Place

2023-06-01

Date (YYYY-MM-DD)



Signature



1.2 UK Declaration of Conformity

Manufacturer

Alfa Laval Kolding A/S, Albuen 31, DK-6000 Kolding, Denmark, phone no. +45 79 32 22 00

Company name, address and phone number

hereby declare that

Valve

Designation

Alfa Laval "Unigue Mixproof CIP"

Type

From serial number 1181354 to 9999999

is in conformity with:

– Supply of Machinery (Safety) Regulations 2008

Signed by authorized representative in UK for and on behalf of: Alfa Laval Kolding A/S

Global Product Quality Manager
Pump, Valves, Fittings and Tank Equipment

Title

Lars Kruse Andersen

Name

Kolding

Place

2023-06-01

Date (YYYY-MM-DD)

Signature



2 Safety



Unsafe practices and other important information are emphasized in this manual.

Warnings are emphasized by means of special signs.

2.1 Important information

Always read the manual before using the Valve!



WARNING

Indicates that special procedures must be followed to avoid serious personal injury.



CAUTION

Indicates that special procedures must be followed to avoid damage to the valve.



NOTE

Indicates important information to simplify or clarify procedures.

This Instruction manual is designed to provide the user with the information to perform tasks safely for all phases in the lifetime of the product supplied.

The user shall always read the safety section first. Hereafter the user can skip to the relevant section for the task to be carried out or for the information needed.

This is the complete manual for the supplied product.

The operators shall read and understand the instruction manual for the supplied product.

Maintenance personnel

The maintenance personnel shall read and understand the instruction manual.

The maintenance personnel or technicians shall be skilled within the field required to carry out the maintenance work safely.

Trainees

Trainees can perform tasks under the supervision of an experienced employee.





People in general

The public shall not have access to the supplied product.

How to contact Alfa Laval Contact details for all countries are continually updated on our website.

Please visit www.alfalaval.com to access the information directly.











2.2 Warning signs

Warnings signs	
	General warning
	Caustic agents
	Cutting danger
	Danger of injury Do NOT attempt to cut the actuator open due to spring under load. (The lock wire opening is locked).
	Danger of injury (lasermarked on the actuator) Do NOT attempt to disassemble the actuator due to spring under load danger! (The lock wire opening is locked)

All warnings in the manual are summarized on this page.

Pay special attention to the instructions below so that severe personal injury and/or damage to the valve are avoided.

2.3 Safety precautions

   	<p>Installation</p> <p>Always read the technical data thoroughly (see Technical data)</p> <p>Always release compressed air after use</p> <p>Never touch the clip assembly or the actuator piston rod if the actuator is supplied with compressed air (see warning label)</p> <p>Never stick your fingers through the valve ports if the actuator is supplied with compressed air</p> <p>Never cut the actuator open, due to spring under load</p> <p>Do NOT attempt to disassemble the actuator due to spring under load danger!</p>
  	<p>Operation</p> <p>Always read the technical data thoroughly (see Technical data)</p> <p>Never touch the clip assembly or the actuator piston rod when the actuator is supplied with compressed air (see warning label)</p> <p>Never pressurise air connections (AC1, AC3) simultaneously as both valve plugs can be lifted (can cause mixing)</p> <p>Never touch the valve or the pipelines when processing hot liquids or when sterilizing</p> <p>Never throttle the leakage outlet</p> <p>Never throttle the CIP outlet, if supplied</p> <p>Always handle lye and acid with great care</p> <p>Make sure to safely collect CIP liquid from drain tube. Tube must be directed towards funnel or drip tray.</p>
   	<p>Maintenance</p> <p>Always read the technical data thoroughly (see Technical data)</p> <p>Always fit the seals correctly</p> <p>Always release compressed air after use</p> <p>Always remove the CIP connections, if supplied, before service. Never service the valve when it is hot</p> <p>Never pressurise the valve/actuator when the valve is serviced</p> <p>Never stick your fingers through the valve ports if the actuator is supplied with compressed air</p> <p>Never touch the clip assembly or the actuator piston rod if the actuator is supplied with compressed air (see warning label)</p> <p>Always use Alfa Laval genuine spare parts. The warranty of Alfa Laval products is dependent on the use of Alfa Laval genuine spare parts</p> <p>Never cut the actuator open, due to spring under load</p> <p>Do NOT attempt to disassemble the actuator due to spring under load danger!</p>

Transportation:

Always ensure that compressed air is released

Always ensure that all connections are disconnected before attempting to remove the valve from the installation

Always drain liquid out of valves before transportation

Always use predesigned lifting points if defined

Always ensure sufficient fixing of the valve during transportation - if specially designed packaging material is available, it must be used

Storage

Ideally, as a guide Alfa Laval recommend:

- Store supplied product as supplied in original packaging
- Port opening should be protected against any ingress
- Bare steel (not stainless) should be lightly oiled/greased
- Store in a clean, dry place without direct sunlight or UV light
- Temperature range -5 to 40°C
- Relative humidity less than 60%
- No exposure to corrosive substances (also air contained)

3 Installation

3.1 Unpacking/delivery

1



Alfa Laval cannot be held responsible for incorrect unpacking.

Check the delivery for:

1. Complete valve
2. Delivery note
3. Warning label

2

Remove upper support

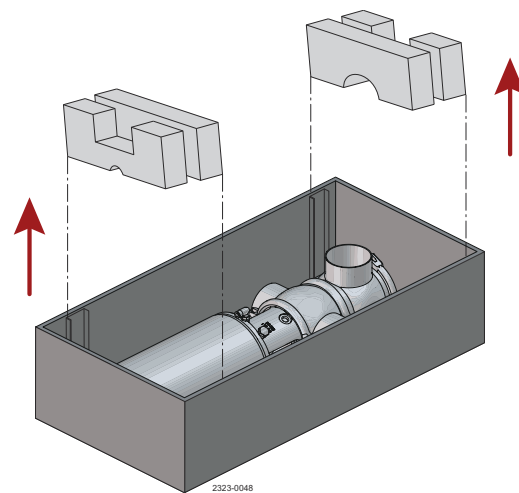

3

Lift out the valve. NOTE! Please note weight of valve as printed on box.

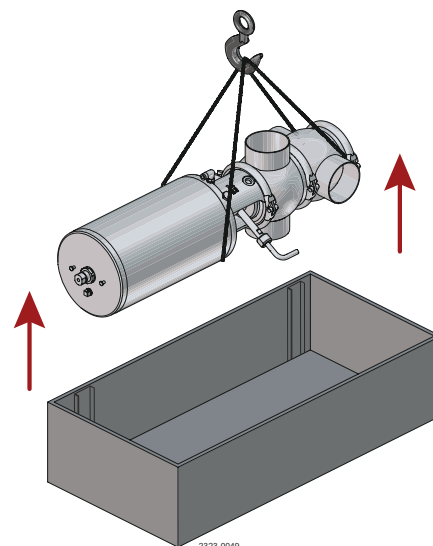

- 4 Remove possible packing materials from the valve ports.

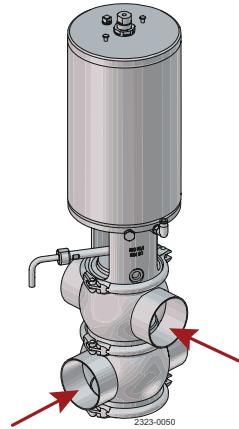

- 5 Inspect the valve for visible transport damages.

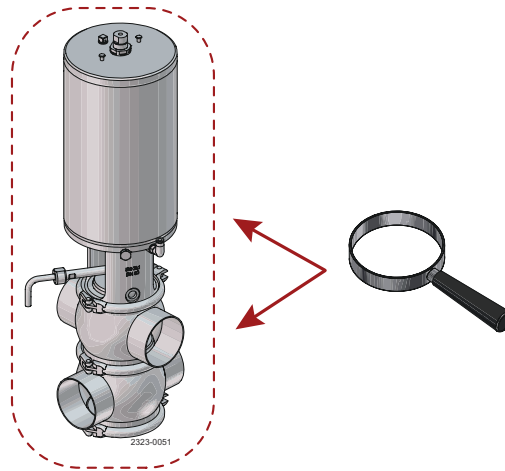

- 6 Avoid damaging the air connections, the leakage outlet, the valve ports and the CIP connections if supplied.

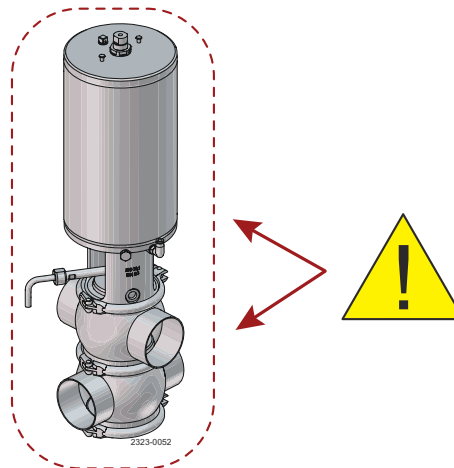

7 Disassemble valve according to illustrations (1 to 7).

1. Supply compressed air to AC2
2. Remove upper clamp (53)
3. Release compressed air
4. Lift out the actuator together with the internal valve parts from valve body (63)
5. Loosen and remove lower clamp (53)
6. Take away lower bonnet (66)
7. Loosen and remove clamp (53) and pull upper (63) and lower (63) valve bodies apart

a = on

b = off

c = air

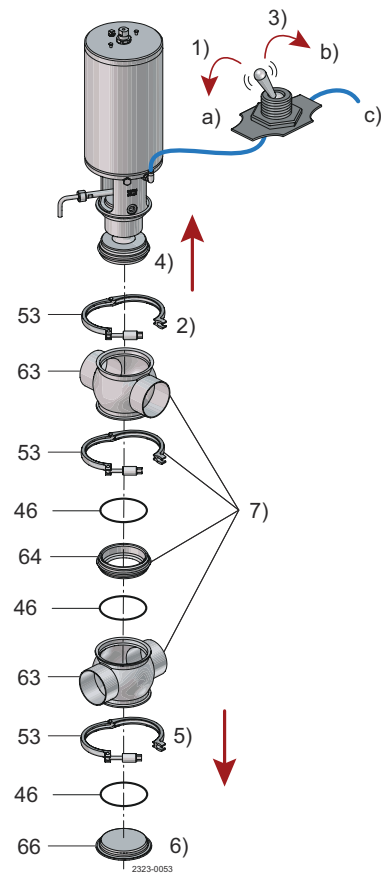

8 1. Place actuator part in the box

2. Add supports

3. Close box and store.

Advise!

Mark the valve body and box with the same number before intermediate storage

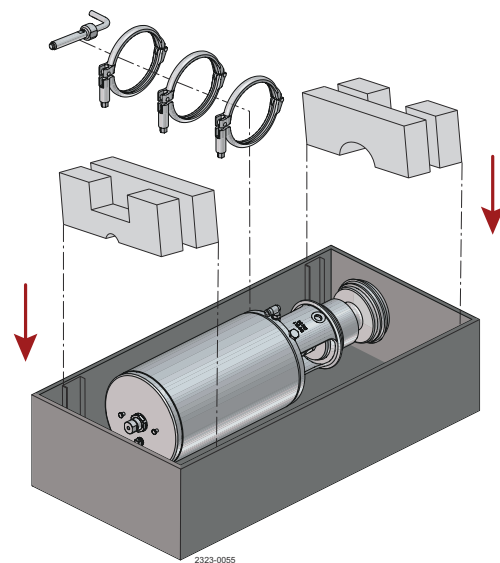

3.2 Installation



The instruction manual is part of the delivery.

Study the instructions carefully.

Fit the warning label supplied on the valve after installation so that it is normally visible.

1

WARNING

Always read the technical data carefully.

See [Technical data](#)

Always release compressed air after use.

Never touch the clip assembly or the actuator piston rod if the actuator is supplied with compressed air (see the warning label).

CAUTION

Fit the supplied warning label on the valve so that it is normally visible.

Alfa Laval cannot be held responsible for incorrect installation.

NOTE

Always install the valve vertically.

The leakage outlet must be turned downwards!

2

Avoid stressing the valve as this can result in deformation of the sealing area and malfunction of the valve (leakage or faulty indication).

Pay special attention to:

- Vibrations
- Thermal expansion of the tubes
- Excessive welding
- Overloading of the pipelines

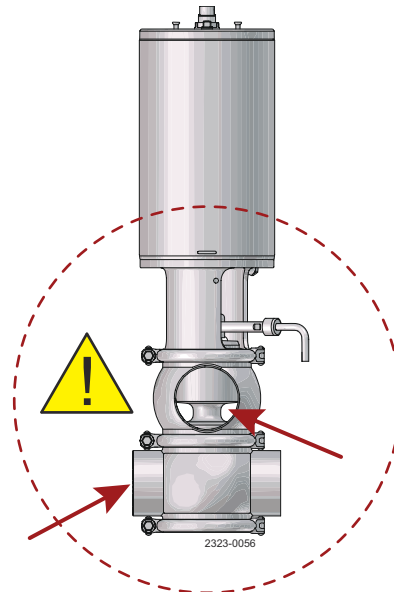

- 3 Fittings: Ensure that the connections are tight.

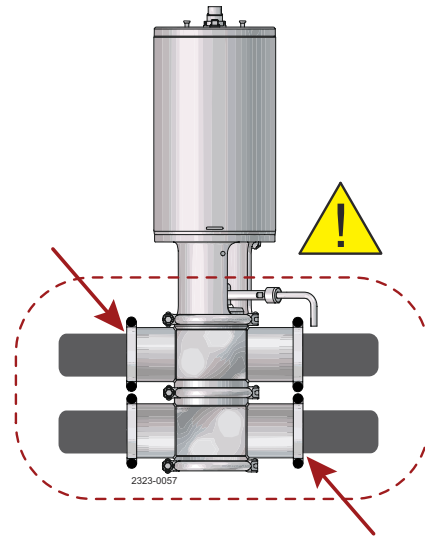

- 4 Air connection: R 1/8" (BSP).

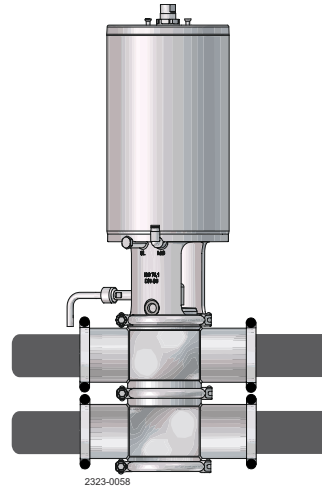

CIP leakage indicator:

1. See description of cleaning in [Recommended cleaning](#)
2. Leakage indicator tube must always be pointing downwards

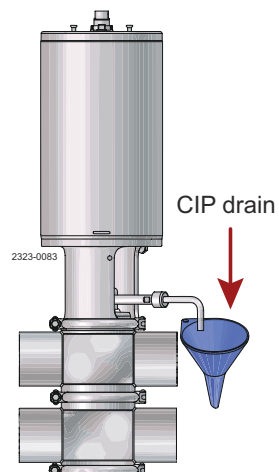

3.3 Welding



Study the instructions carefully and pay special attention to the warnings!
 The valve has ends for welding as standard.
 Weld carefully/aim at stressless welding to avoid deformation on sealing areas.
 Check for valve for smooth operation after welding.

1



WARNING

Never stick your fingers through the valve ports if the actuator is supplied with compressed air.

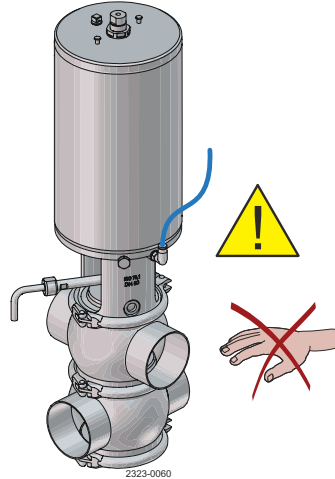

2

Dismantle the valve in accordance with Step 1 in *Dismantling the valve*.

3



NOTE

Maintain the minimum clearances so that the actuator with the internal valve parts can be removed - please see later this section!



WARNING

If there is a risk of foot damage, Alfa Laval recommends to leave a distance of 120 mm (4.7") below the valve (look at the specific built-in conditions).

4



WARNING

Make sure to turn the valve seat correctly - conical valve seat upwards.

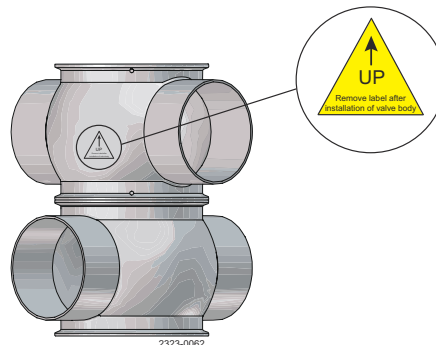

5 Assemble the valve in accordance with *Valve assembly* after welding. Pay special attention to the warnings!

6 Pre-use check:
 1. Supply compressed air to MS.
 2. Operate the valve several times to ensure that it runs smoothly. Pay special attention to the warnings!

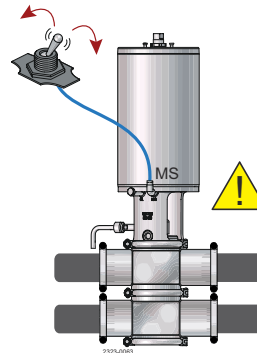

NOTE
 If ThinkTop® is mounted, add 180 mm (7.1") to B measure.

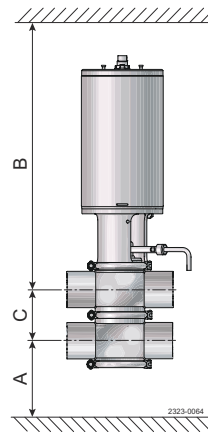

Table 1
 (All measures in mm) (1mm = 0.0394")

Size	ISO				DIN			
	DN/OD	DN/OD	DN/OD	DN/OD	DN	DN	DN	DN
	51	63.5	76.1	101.6	50	65	80	100
A	70	78	86	95	70	78	86	95
B	450.8	469.6	577.9	614.9	454.1	478.1	590.0	623.5
C	73.8	86.3	98.9	123.6	76	92	107	126

* The measure C can always be calculated by the formula $C = \frac{1}{2} ID \text{ upper} + \frac{1}{2} ID \text{ lower} + 26 \text{ mm (1")}$.

3.4 Recycling Information

Unpacking



- Packing material consists of wood, plastics, cardboard boxes and in some cases metal straps.
- Wood and cardboard boxes can be reused, recycled or used for energy recovery
- Plastics should be recycled or burnt at a licensed waste incineration plant
- Metal straps should be sent for material recycling

Maintenance

During maintenance oil and wear parts in the machine are replaced.

- Oil and all non-metal wearing parts must be disposed of in accordance with local regulations
- Rubber and plastics should be burnt at a licensed waste incineration plant. If not available they should be disposed in accordance with local regulations
- Bearings and other metal parts should be sent to a licensed handler for material recycling
- Seal rings and friction linings should be disposed to a licensed land fill site. Check your local regulations
- All metal parts should be sent for material recycling
- Worn out or defected electronic parts should be sent to a licensed handler for material recycling

Scrapping

- At end of use, the equipment must be recycled in accordance with the relevant local regulations. Besides the equipment itself, any hazardous residues from the process liquid must be considered and dealt with in a proper manner. When in doubt, or in the absence of local regulations, please contact your local Alfa Laval sales company.



Do **NOT** attempt to disassemble the actuator due to spring under load danger!



Do **NOT** attempt to cut the actuator open, due to spring under load danger!

4 Operation



The valve is adjusted and tested before delivery.

Study the instructions carefully and pay special attention to the warnings!

Pay attention to possible fault.

The items refer to the parts list.

1

**WARNING**

Always read the technical data carefully.

See [Technical data](#)

Always release compressed air after use.

Never touch the clip assembly or the actuator piston rod if the actuator is supplied with compressed air (see the warning label).

Never pressurise air connections simultaneously as both valve plugs can be lifted (can cause mixing).

**CAUTION**

Alfa Laval cannot be held responsible for incorrect operation.

2

**WARNING**

Never touch the valve or the pipelines when processing hot liquids or when sterilising.

The valve is adjusted and tested before delivery.

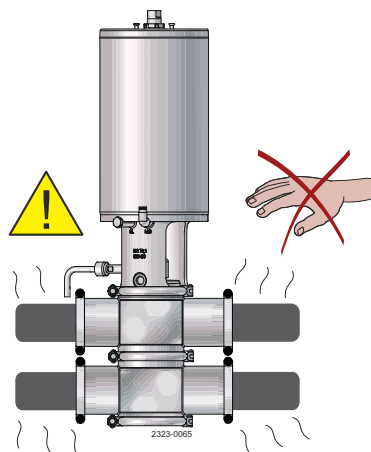

4.1 Fault finding and repair



Study the instructions carefully and pay special attention to the warnings!
Pay attention to possible faults.
The item refer to the part s list.

NOTE

Study the maintenance instructions carefully before replacing worn parts.

Problem	Cause/result	Repair
Leakage at sealing element (47)/upper plug (50)	Worn/product affected O-rings/lip seal (45/48)	<ul style="list-style-type: none"> • Replace the O-rings/lip seal • Change rubber grade • Clean and if necessary replace guide ring (45)
Leakage at clamp (53)	<ul style="list-style-type: none"> • Too old/product affected O-rings (and 46 if clamped valve body) • Loose clamp (53) 	<ul style="list-style-type: none"> • Change rubber grade • Tighten the clamp
CIP leakage	Worn O-rings (60/61)	Replace the O-rings
Leakage at spindle clamp (43)	Damaged O-ring (61) Worn/product	<ul style="list-style-type: none"> • Replace the plug seals • Change rubber grade
Lower plug not returning to closed position	<ul style="list-style-type: none"> • Wrong rubber grade • Wrongly fitted gasket • Mounted incorrectly (see section 2.3) 	<ul style="list-style-type: none"> • Change rubber grade • Fit new gasket correctly • Correct installation
Plug returns with uneven movements (slip/stick effect)	<ul style="list-style-type: none"> • Wrong rubber grade • Wrongly fitted gasket • Mounted incorrectly (see section 2.3) 	<ul style="list-style-type: none"> • Change rubber grade • Fit new gasket correctly • Correct installation

4.2 Recommended cleaning



The valve is designed for cleaning in place (CIP).

CIP = Cleaning In Place. Study the instructions carefully and pay special attention to the warnings!

NaOH = Caustic Soda. HNO₃ = Nitric acid.

Internal leakage in the valve is externally visible by means of the leakage outlet.

1



WARNING
Never touch the valve or the pipelines when sterilising.

Caution danger!



Always use rubber gloves! Always use protective goggles!

2



WARNING
Never touch the valve or the pipelines when sterilising.

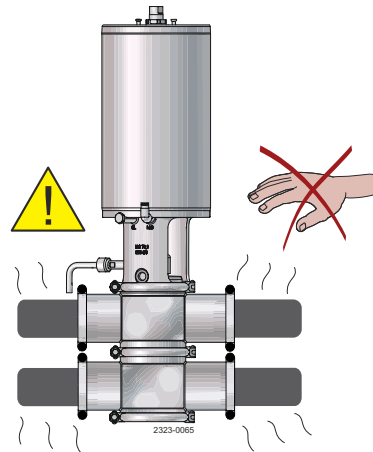

3



WARNING
Never throttle the leakage indicator.

a = CIP drain

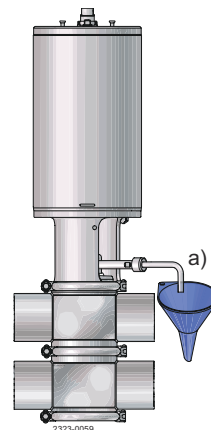

4 Examples of cleaning agents: Use clean water, free from chlorides.

1. 1% by weight NaOH at 70°C (158°F).

1 kg(2.2 lb) NaOH	+	100 l (26.4 gal) water	=	Cleaning agent.*)
----------------------	---	---------------------------	---	-------------------

2.2 l (0.6 gal) 33% NaOH	+	100 l (26.4 gal) water	=	Cleaning agent.**)
-----------------------------	---	---------------------------	---	--------------------

*) Avoid excessive concentration of the cleaning agent ⇒ Dose gradually!

***) Adjust the cleaning flow to the process. Sterilisation of milk/viscous liquids ⇒ Increase the cleaning flow!

2. 0.5% by weight HNO₃ at 70°C (158°F).

0.7 l (0.2 gal) 53% HNO ₃	+	100 l (26.4 gal) water	=	Cleaning agent.
---	---	---------------------------	---	-----------------

5



WARNING

Always rinse well with clean water after using a cleaning agent.



NOTE

The cleaning agents must be stored/disposed of in accordance with current regulations/directives.

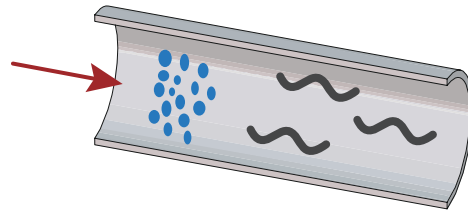

3013-0153

5 Maintenance



Maintain the valve/actuator regularly.

Study the instructions carefully and pay special attention to the warnings!

Always use Alfa Laval genuine spare parts, and keep rubber seals and guide rings in stock.

Internal leakage in the valve is externally visible.

Check the valve for smooth operation after service.

5.1 General maintenance

1

WARNING

Always read the technical data carefully.

See [Technical data](#)

Always fit the seals correctly (risk of mixing)

Always release compressed air after use

NOTE

All scrap must be stored/discharged in accordance with current rules/directives.

2

WARNING

Never service the valve when it is hot.

Never service the valve with valve/actuator under pressure.

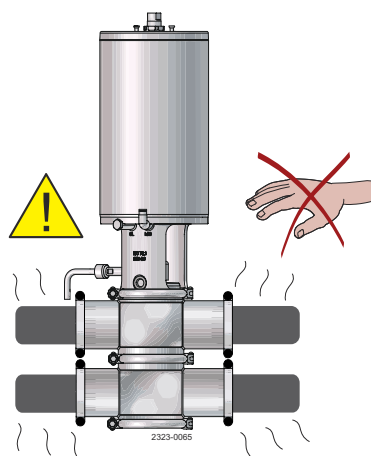

3

WARNING

Never stick your fingers through the valve ports if the actuator is supplied with compressed air.

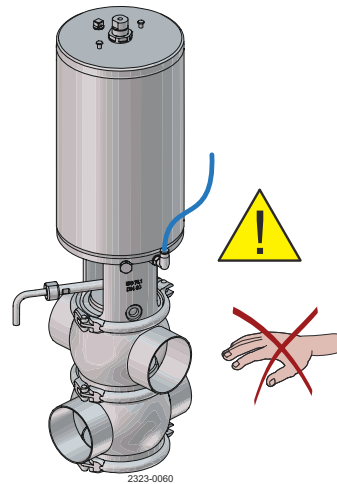

4

WARNING

Never touch the clip assembly or the actuator piston rod if the actuator is supplied with compressed air (see the warning label).

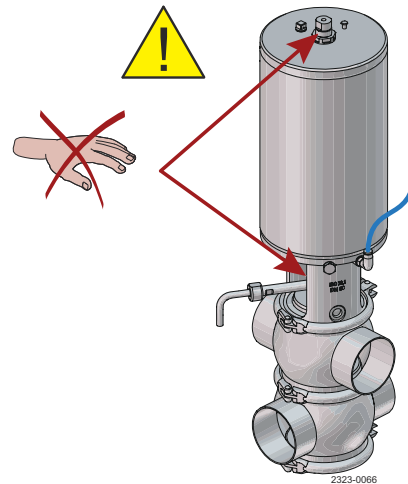

Recommended spare parts: Service kits

Order service kits from the service kits section - see [Parts list](#)

Ordering spare parts: Contact the Sales Department.

5.2 Actuator Bushing Replacement (Non-maintainable Actuator)

WARNING

Do **NOT** attempt to disassemble it.

The spring inside is under load – any type of breakage of the actuator can lead to severe injury or even death!



Introduction

- The actuator service kit contains one bushing and two O-rings
- Mount the thick O-ring inside and the thin O-ring outside the bushing
- Lubricate the stem and O-rings with "Molykote Longterm 2 Plus" or an equivalent grease before sliding the new bushing onto the actuator stem

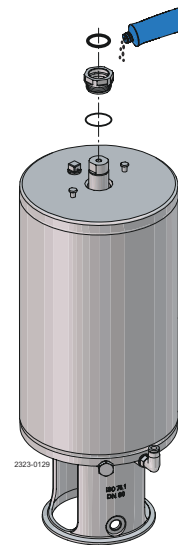

Introduction - Standard tubular box wrench

Use a 27 mm (1 1/16") tubular box wrench to unmount and/or mount the bushings.

This tool will allow the actuator stem to fit inside and will provide good access to the bushing placed in the actuator yoke end.

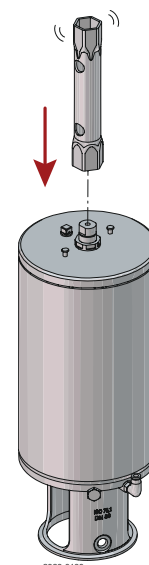

Introduction - Aligning spindle

The actuator spindle can in some cases be forced off centre by the internal spring, as shown.

In cases with misalignment of the actuator stem in relation to the bushing thread, as shown, the tubular box wrench together with a spindle for alignment and an adapter are a great help and will ensure a reliable mounting of the bushing.

The aligning spindle can be purchased from Alfa Laval (**9614198401**) which also include a 27 mm(1 1/16") tubular box wrench.

Spindle forced off centre by spring inside actuator

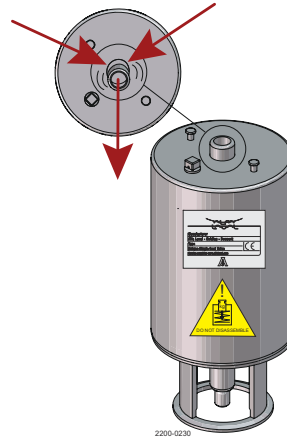

1

The actuator must be fixed in a vice, Alfa Laval recommend use of soft jaws.

Be careful not to damage the yoke by over tightening and only fix carefully on the "yoke leg", as shown.

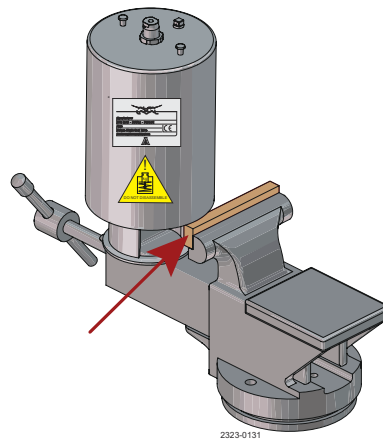

2

Slide the lubricated bushing onto the actuator stem.

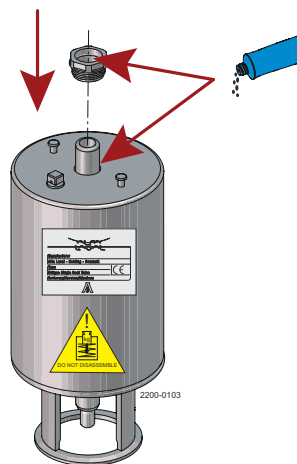

3

Fit the aligning spindle to the actuator stem using adapter and apply the tubular box wrench.

Aligning spindle

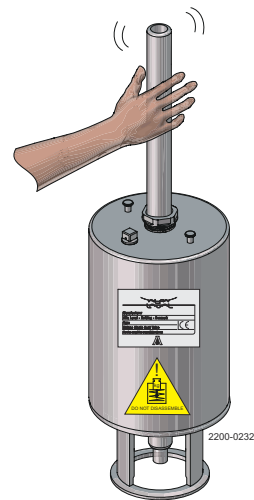

Tubular box wrench

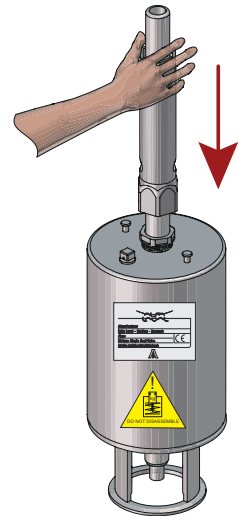

4

Now pull the aligning spindle to center the actuator stem in relation to the bushing thread. When centered, initiate fastening of the bushing. Ensure the thread catches evenly!

The bushing must only be tightened with a torque of 10 Nm (7 lb-ft) which is achievable by hand tightening only.

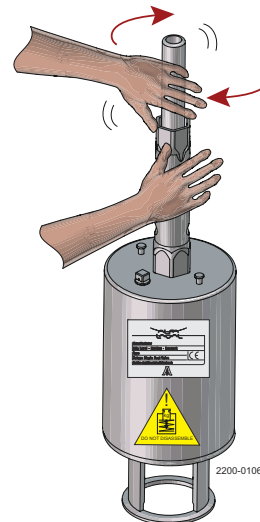

5.3 Dismantling the valve



Study the instructions carefully

The items refer to the parts list.

carefully and pay special attention to the warnings!

Handle scrap correctly.

Always use Alfa Laval genuine spare parts. Replace seals if necessary.

1 Disassemble valve according to illustrations (1 to 7).

1. Supply compressed air to MS
2. Remove upper clamp (53)
3. Release compressed air
4. Lift out the actuator together with the internal valve parts from valve body (63)
5. Loosen and remove lower clamp (53)
6. Take away lower bonnet (66)
7. Loosen and remove clamp (53) and pull upper (63) and lower (63) valve bodies apart. Remove O-rings

a = on

b = off

c = air

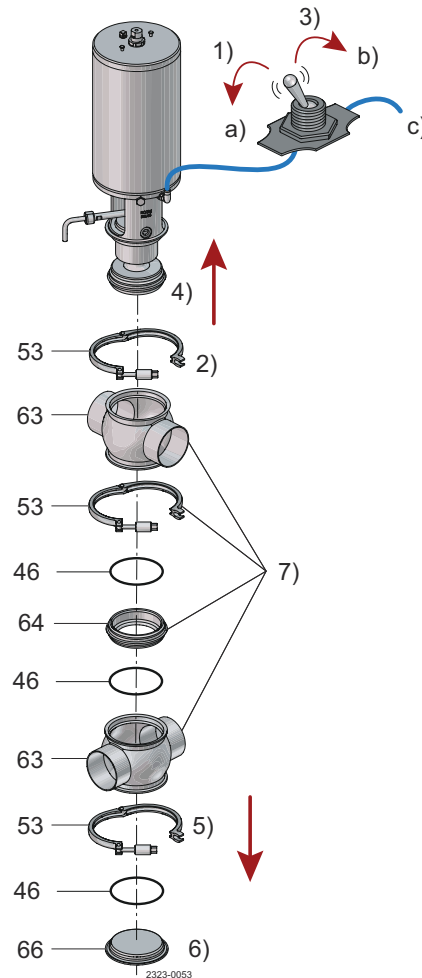

- 2**
1. Loosen lower plug (65) while counter holding upper stem
 2. Remove the lower plug (65)
Remove O-ring (55)

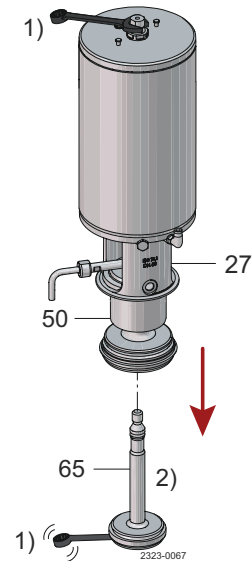

- 3**
- Remove coupling system and upper plug.
1. Unscrew leakage indicator tube (67).
Remove O-ring (60)
 2. Pull up lock (44) over piston rod
 3. Pull away clamps (43) from spindle liner (42)
 4. Pull out upper plug (50). Make sure spindle liner is free of both piston rod and upper plug. Remove O-rings (61)

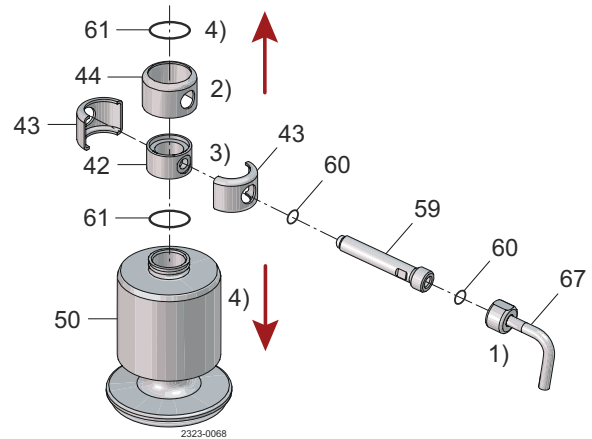

- 4**
1. Pull out upper sealing element (47) from yoke
 2. Pull out O-ring (46), lip seal (48) and guide ring (45) from upper sealing element

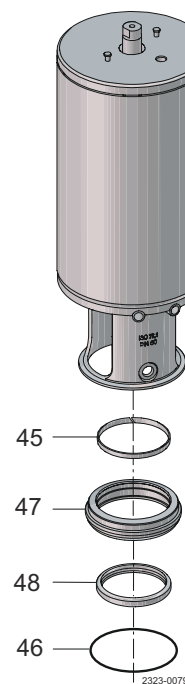

5.4 Upper and lower plug seal replacement

DN 50 51 mm	DN 65 63.5 mm	DN 80 76.1 mm	DN 100 101.6 mm
8010028280	8010028191	8010028311	8010028184

1

- Remove old seal ring using a knife, screwdriver or similar. Be careful not to damage the plug surface. If using a screwdriver it must be placed underneath the plug groove (see Figure 1).
- Grease the new seal ring with Alfa Laval Silicone Based, which is included in the service kit. Only use a very small amount of grease.
- Fit the seal ring on the plug without pressing it into the groove. Be careful not to twist the seal ring. Use a screwdriver (two turns) to fit the seal ring properly and to ensure it is not twisted (see Figure 2).
- The seal ring can now be mounted by hand or with the Alfa Laval plug tool.

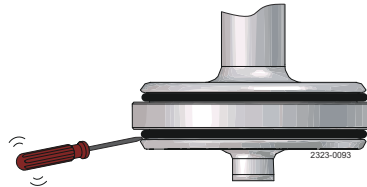

Figure 1:

It is important to place the screwdriver underneath the plug.

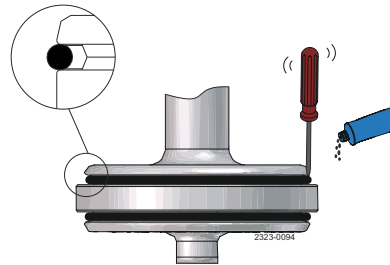

Figure 2:

2 Mounting plug seal ring by hand

1. Check the seal ring is premounted as described in step 1.

To ensure correct mounting, press with your thumb on the seal ring, which must be done approximately 10 times and always with opposite pressure points, from A to B, to C and D (see Figure 3).

The rest of the seal ring can now be pressed into the groove so the whole seal ring is mounted. Check that there are NO "bulge" (see Figure 4).

If there is a little bulge – then use the screwdriver to eliminate the bulge.

Again press with the thumb on the seal ring and keep the pressure while rotating 360° (see Figure 3).

2. It is important to release compressed air behind the seal ring.

This is done with a screwdriver and always underneath the plug see Figure 1. It must be done at one or two different points on the circumference.

Be careful not to make marks on the surface of the plug and seal ring.

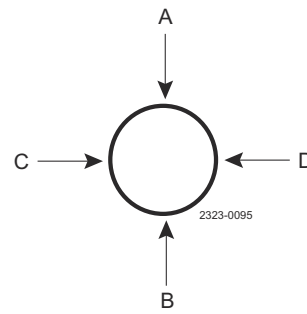

Figure 3:

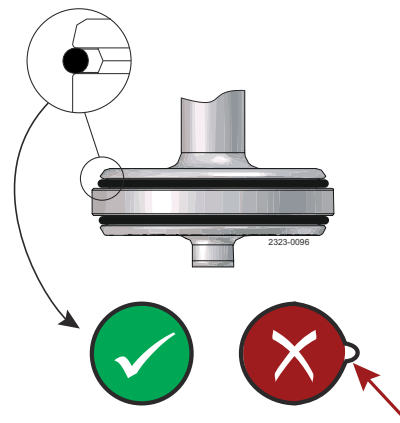
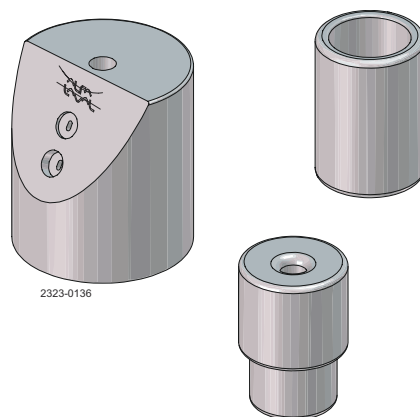

Figure 4:

3 Mounting plug seal ring with Alfa Laval plug seal tool



1. Part A

“Part A” has an upper and lower exhaust hole.
The upper exhaust hole is for the lower plug and the lower exhaust hole is for the upper plug.

2. Part B

Used for mounting seal on lower plug.

3. Part C

Used for mounting seal on upper plug.

Fit the plug spindle in “part B” or “part A”.

Place “part A” onto “part B” and then press “hard” down on the top of “part A”.

Now fit the screwdriver into the exhaust hole and underneath the plug groove meanwhile keeping the pressure on “part A”.

This should ensure correct removal of air behind the seal ring. Normally the sound “Pssst” can be heard one time.

A “drill press” can of course also be used to press down on “part A”.

4. It is important to release compressed air behind the seal ring.

This is done with a screwdriver and always underneath the plug.

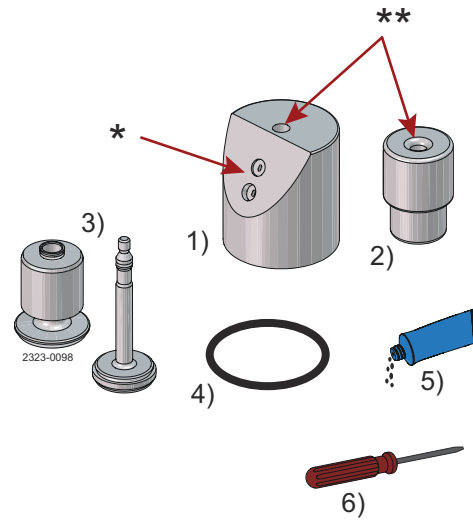

1. Part A

2. Part B

3. Plugs

4. O-ring

5. Grease Alfa Laval Silicone based lubrication from service kit

6. Screwdriver (no sharp corner)

*) Exhaust holes for screwdriver

***) Ø20 hole for plug spindle

5.5 Valve assembly

- 1
1. Fit O-ring (46) (do not twist), lip seal (48) and guide ring (45) in upper sealing element (47) (Lubricate with Alfa Laval Lubricant)

NOTE

The O-ring should be gently pressed into the groove

2. Fit upper sealing element in yoke

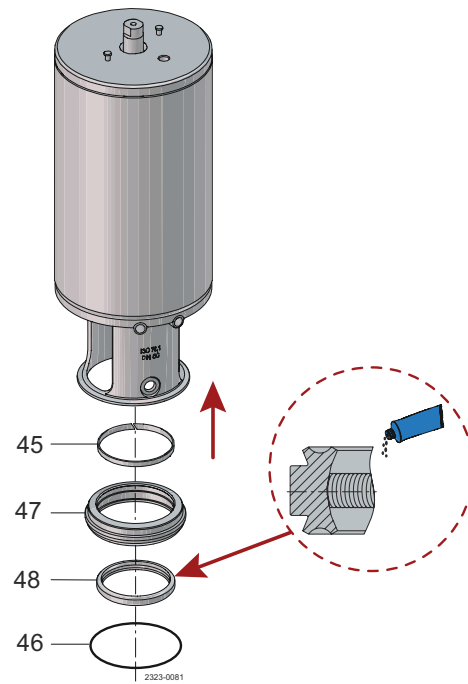

- 2
1. Fit O-ring (55) in the lower plug (65)
 2. Mount lower plug (65) into upper plug (50) through the lip seal

NOTE

Do not damage the lips when lower plug (65) with O-ring (55) passes the lip seal.

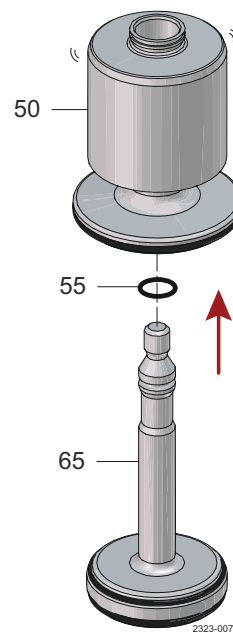

3 Place coupling system and upper plug

1. Place O-rings (61)
2. Push lock (44) up over piston rod (21)
3. Place O-rings (61)
4. Place spindle liner (42) on piston rod. Fit upper plug (50)
5. Mount clamps (43) on spindle liner (42)
6. Fit lock (44)
7. Fit O-ring (60). Fit leakage indicator tube (67)

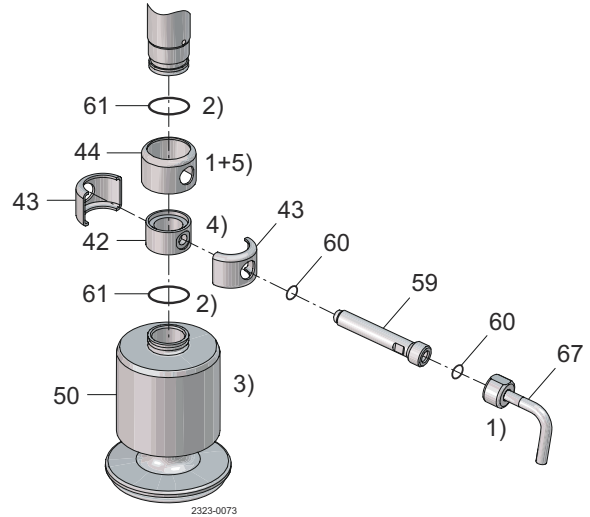

4 Recommended torque values for fitting lower plug parts is 20 Nm / 14.8 lbf-ft.

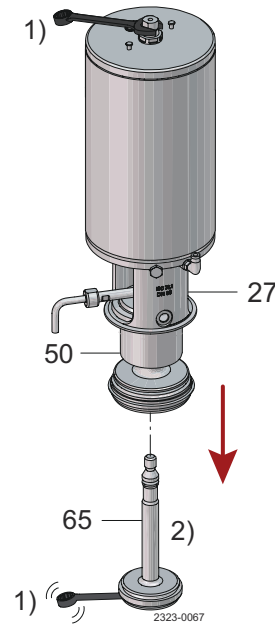

5



WARNING
Never stick your fingers through the valve ports if the actuator is supplied with compressed air

Always supply compressed air, before demounting the valve

Reassemble valve

1. Place O-ring (46) on bonnet (66) and insert into valvebody (63). Fit and tighten clamp (53)
2. Place O-rings (46) on valveseat (64) and insert valveseat in lower valvebody (63), fit upper valvebody (63) and fit and tighten clamp
3. Supply (53) compressed air and mount the actuator together with the internal valve parts from valve body (63)
4. Fit and tighten upper clamp (53). Greasing of clamp and clamp nut recommended!
(Maximum torque for clamp nut: 10Nm/7.4 lbf-ft)
5. Release compressed air

a = on

b = off

c = air

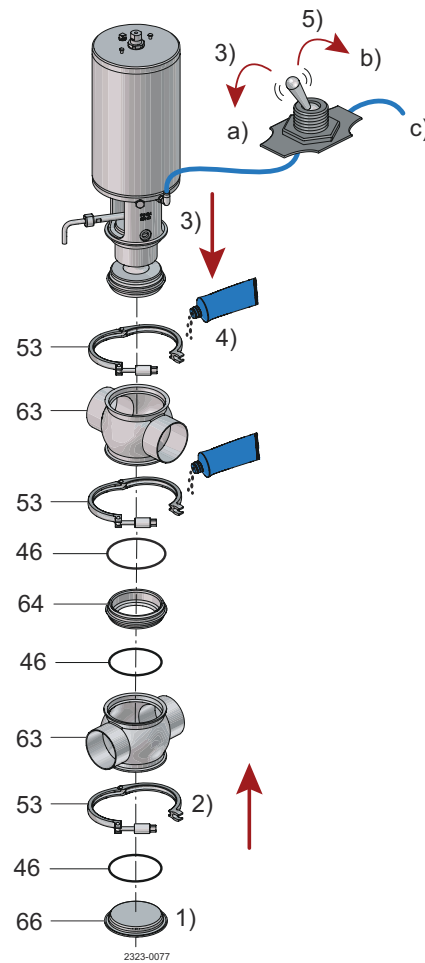

6 Technical data



Study the instructions carefully.

The items refer to the part list.

Handle scrap correctly.

Always use Alfa Laval genuine spare parts. Replace seals if necessary.

The valve is remote-controlled by means of compressed air. The valve is a normally closed (NC) valve.

The valve has two independent plug seals, forming a leakage chamber between them under atmospheric pressure during every working condition. In case of rare accidental leaking of product, this will flow into the leakage chamber and be discharged through the leakage outlet.

Data

Max. product pressure:	1000 kPa (10 bar) (145 PSI)
Min. product pressure:	Full vacuum
Temperature range:	-5°C to +140°C (23°F - 284°F) EPDM (Depending on rubber quality)
Air pressure:	600-800 kPa (6-8 bar) (87-116 PSI)
Products acc. to 2014/68/E	Category I, Fluids group 1

Data

Materials

Product wetted steel parts:	Stainless steel AISI 316L
Other steel parts:	Stainless steel AISI 304
Product wetted seals:	EPDM, HNBR or FPM
Other seals:	CIP seals: EPDM
Actuator seals:	NBR
Surface finish:	External matt (blasted) Ra < 1.6 (64 µl") Internal bright (polished) Ra < 0.8 (32 µl")

NOTE

The Ra-values are only for the internal surface.

Weight (kg)

Size	DN/OD				DN			
	51	63.5	76.1	101.6	50	66	80	100
Weight (type 22)	10.7	12.9	22.2	25.0	10.8	13.2	22.7	25.1
Weight (type 30)	9.9	11.5	20.3	21.8	9.9	11.7	20.6	21.9

Weight (Inch)

Size	DN/OD			
	51	63.5	76.1	101.6
Weight (type 22)	23.6	28.4	49.0	55.1
Weight (type 30)	21.8	25.4	44.8	48.1

Safety check

A visual inspection of any protective device (shield, guard, cover or other) on the supplied product shall be carried out at least every 12 months.

If the protective device is lost or damaged, especially when this leads to deterioration of safety performance, it shall be replaced. The fixing of the protective device should only be replaced with fixings of the same or an equivalent type.

Inspection acceptance criteria:

- It should not be possible to reach moving parts originally protected by a protective device
- The protective device must be securely mounted
- Ensure that screws for the protective device are securely tightened

Procedure in case of non-acceptance:

- Fix and/or replace the protective device

Size	DN/OD				DN			
ISO/DIN	51	63.5	76.1	101.6	50	65	80	100
Kv-value [m ³ /h]	34.4	52.2	104.3	163.3	34.4	52.2	104.3	163.3
Cv-value [gpm/psi]	39.8	60.4	120.5	188.8	39.8	60.4	120.5	188.8

Size	DN/OD				DN			
ISO/DIN	51	63.5	76.1	101.6	50	65	80	100
Air consumption								
Main Movement [n litre]	0.64	0.64	1.48	1.48	0.64	0.64	1.48	1.48
Main Movement [cubic inches]	38.84	38.84	90.48	90.48	38.84	38.84	90.48	90.48

NOTE

* [n litre] = volume at atmospheric pressure.

Formula to estimate CIP flow during seat lift (for liquids with comparable viscosity and density to water):

- $Q = K_v \sqrt{\Delta p}$
- Q = CIP - flow (m³/h)
- K_v = K_v value from the above table
- Δp = CIP pressure (bar)
- Cv = 1.163 x Kv gpm
- 1 bar = 14.5 PSI

7 Spare Parts

For every delivered Alfa Laval Product, a spare part list is available.

This spare part list contains a range of the most common wear parts for the machinery. If any component not mentioned is required, please contact your local Alfa Laval representative for availability.

You can find our spare part catalogue at <https://hygienicfluidhandling-catalogue.alfalaval.com/>

Always use Alfa Laval genuine spare parts. The warranty of Alfa Laval products is dependent on use of Alfa Laval genuine spare parts.

7.1 Ordering Spare Parts

When ordering spare parts, please always state:

1. Serial number (if available)
2. Item number/spare part number (if available)
3. Capacity or other relevant identification

7.2 Alfa Laval Service

Alfa Laval is represented in all larger countries of the world.

Do not hesitate to contact your local Alfa Laval representative, with any questions or requirement of spare parts for Alfa Laval equipment.

8 Parts list and exploded view

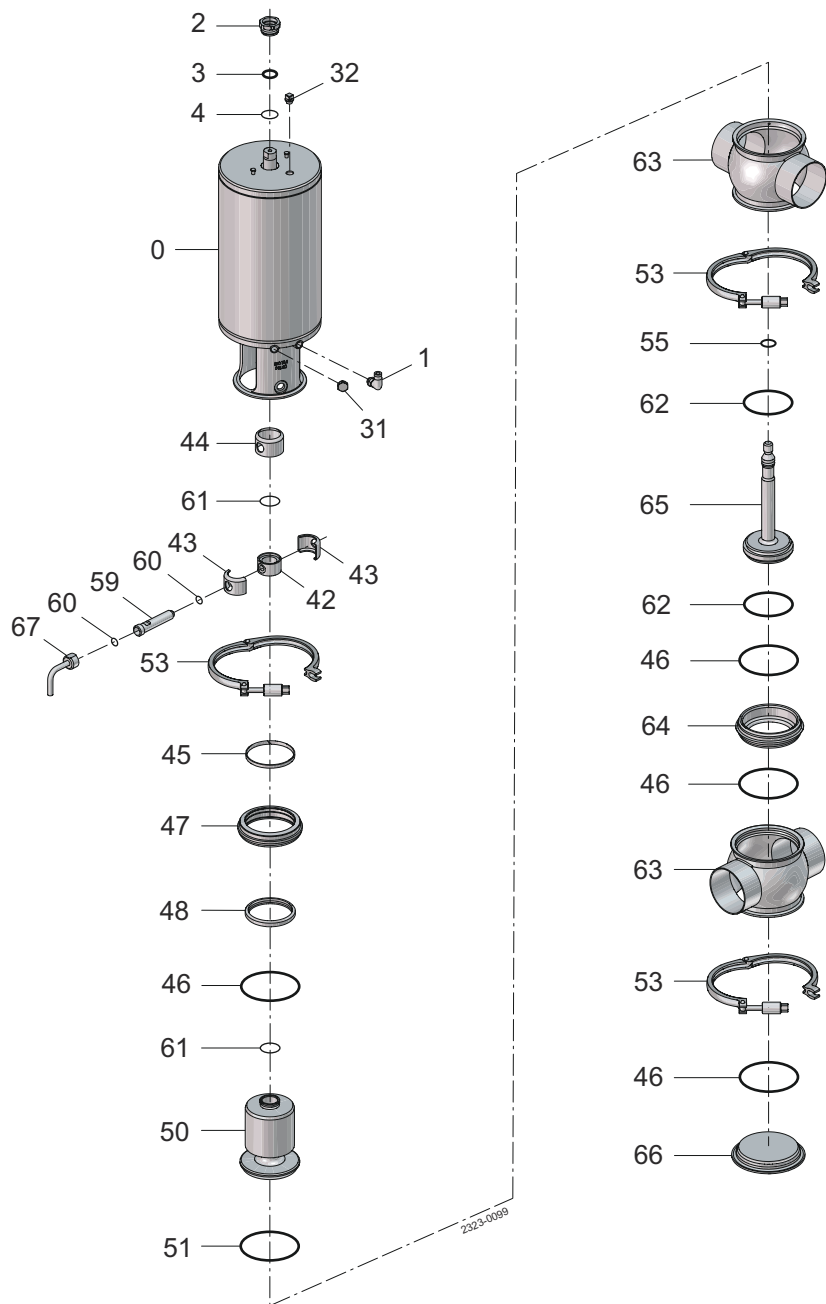

Pos.	Qty	Denomination
0	1	Actuator
1	1	Air fitting
2	1	Bushing
3	1	O-ring
4	1	O-ring
31	1	Plug
32	1	Air release plug
42	1	Spindle liner
43	2	Clamp
44	1	Lock
45	1	Guide ring
46	4	O-ring
47	1	Sealing element, upper
48	1	Lipseal
50	1	Plug, upper
51	1	Plug seal
53	3	Clamp
55	1	O-ring
59	1	Flushing tube
60	2	O-ring
61	2	O-ring
62	2	Plug seal
63	2	Valve body
64	1	Valve seat
65	1	Plug, lower
66	1	Blank
67	1	Drain pipe

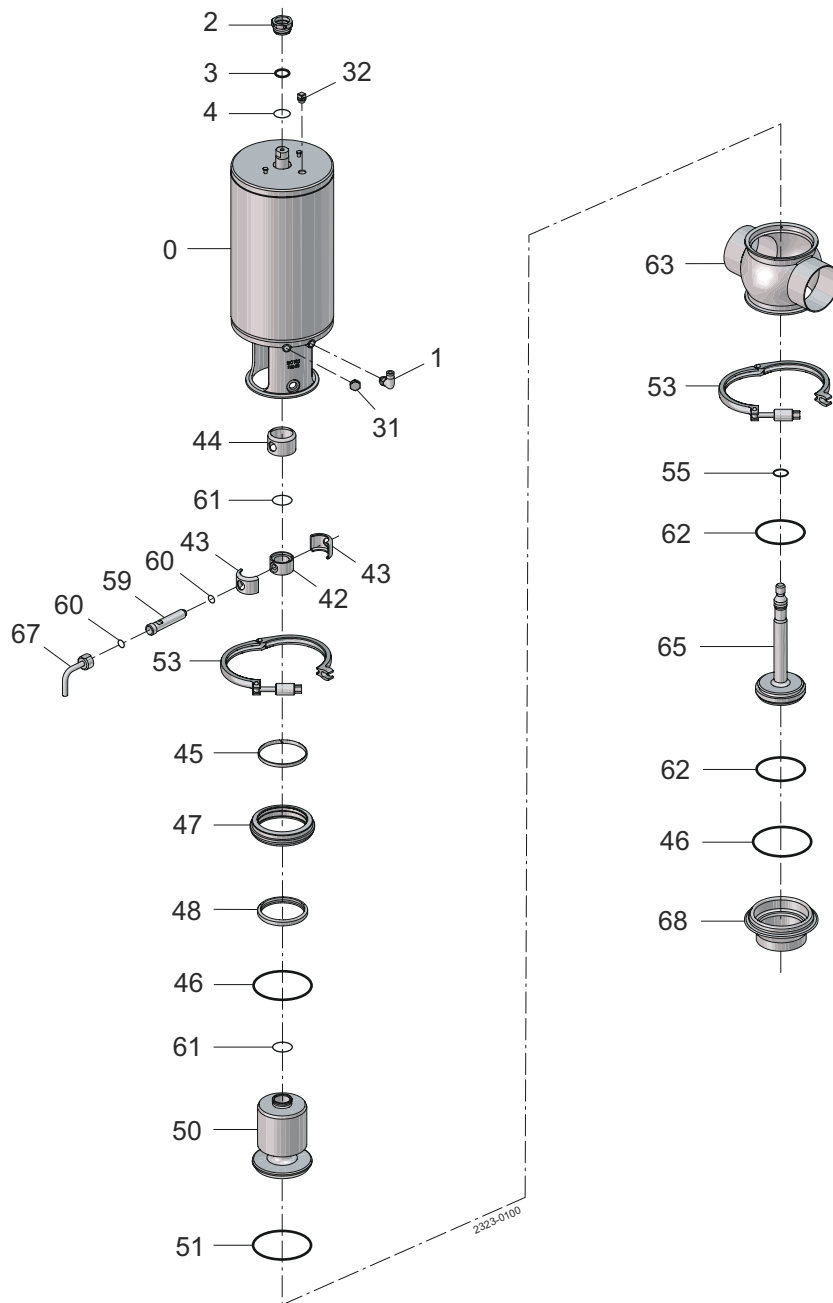

Pos.	Qty	Denomination
0	1	Actuator
1	1	Air fitting
2	1	Bushing
3	1	O-ring
4	1	O-ring
31	1	Plug
32	1	Air release plug
42	1	Spindle liner
43	2	Clamp
44	1	Lock
45	1	Guide ring
46	4	O-ring
47	1	Sealing element, upper
48	1	Lipseal
50	1	Plug, upper
51	1	Plug seal
53	2	Clamp
55	1	O-ring
59	1	Flushing tube
60	2	O-ring
61	2	O-ring
62	2	Plug seal
63	1	Valve body
65	1	Plug, lower
67	1	Drain pipe
68	1	Port seal